

THANK YOU!

You have successfully downloaded your **FREE** PlansNOW.com woodworking plan.

► [Go to Page 1](#)

Tips for Trouble-Free Printing

Clear printer memory. If you are unable to print this document, turn off your printer for at least 15 seconds and try again.

Get advanced printer help. Visit [Adobe Support](http://www.adobe.com/support/techdocs/150d6.htm) for instructions in troubleshooting common printer problems. www.adobe.com/support/techdocs/150d6.htm

A Plan for Every Project! See more than 250 Plans at PlansNOW.com



[Workbench Plans](#)

Sound woodworking starts with a solid workbench.



[Bedroom Furniture Plans](#)

Beds, dressers, armoires, cribs, cradles, and more!



[Shop Jig Plans](#)

Get the most from your tools with easy-to-build shop jigs.



[Craftsman Furniture Plans](#)

Build the same distinctive features from the early 1900s.



[Home Improvement Plans](#)

Save hundreds of dollars in remodeling when you DIY.

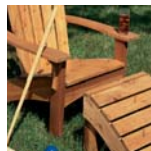

[Outdoor Furniture Plans](#)

Easy-to-build projects using a minimum of power tools.



[Playhouse & Shed Plans](#)

Everything you'll need for a kid's summer entertainment.



[Gazebo & Arbor Plans](#)

Make outdoor living more enjoyable this summer!

[Visit us at www.PlansNOW.com](http://www.PlansNOW.com)

CLAMPING & ASSEMBLY

The secrets to goof-proof glue-ups are found in what you do after the pieces are cut and before the glue goes on.

Before reaching for the glue bottle, I always pause and take a deep breath. Once the glue is applied, there's no turning back. It will start to set in just a few minutes, so things have to go right the first time.

It doesn't matter what size or shape the assembly is — an edge-to-edge panel or flat frame, simple drawer or large carcass, thin edging strips or a large tabletop lamination. Each has its own challenges — and solutions (which I'll get to in a minute). But there are still some basic steps that I always try to take with every assembly.

ASSEMBLY SURFACE. The first thing needed is a flat work surface. If it's not, you'll have to work that much harder to get your assembly flat and square. (Or you may not notice a problem before it's too late.)

A workbench is a natural assembly table, but for smaller projects, a table saw is another good choice. (Be sure to protect the top surface with paper.) And for large projects, I lay down a solid-core door to even out the bumps in my shop floor.

LABEL PARTS. Another ingredient for a smooth assembly is organization. The time to figure out top from bottom and left from right is before the



glue goes on. For a flat panel, like the one in Fig. 1, a “carpenter’s triangle” drawn across the boards will help you get them back in the same orientation quickly. And by writing labels on mating pieces of frame and case assemblies (Fig. 2), it’ll take just a glance to tell which pieces go together *and* in what orientation.

DRY ASSEMBLE. But I find the most important part of a successful glue-up (and the easiest to shortchange) is the dry assembly. Clamping up

the project without glue can help you find problems, so you can solve them without getting frantic. For example, you may discover that pieces need to go together in a particular order. Or that you don't have enough hands to get parts together in the time it would take before the glue cures. It's best to know this before the glue goes on so you can call in a helper if needed.

FLAT ASSEMBLIES

Gluing up panels from two or more boards is one of the most common glue-ups you're going to face. Another is putting simple frames together. Both assemblies must end up flat with strong, tight joints.

CLAMP COVERAGE. One thing to think about (especially when gluing up panels) is the number of clamps you'll need to pull the joints tight. The reason has to do with how clamping pressure is distributed.

As you can see in Fig. 1, clamping pressure extends out at about 45°

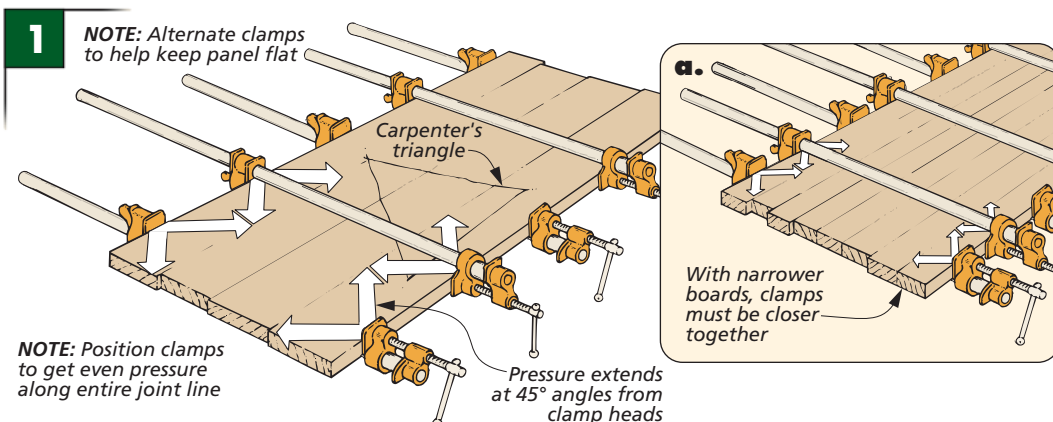

angles from the head (and foot) of a clamp. With a wider board, a clamp covers a wider area. The idea is to use enough clamps to apply pressure along the full length of the joint lines. This means when working with narrower boards, you'll need to have a few more clamps on hand to pull everything tight (Fig. 1a).

CENTERING PRESSURE. Besides having enough clamps, you also want to make sure the pressure is centered on the *thickness* of the pieces. And since boards resting on the pipes or bars of the clamps often sit below the screws of the clamp, the pressure is applied *down* as well as into the joint. The result is an assembly that tends to buckle and joint lines that refuse to close up.

With panels, a simple solution is to alternate the clamps above and below the panel, as shown in Fig. 1. But even here, the boards may shift up or down at a joint line, causing a “bump” in the surface. At the ends of the workpieces, you can use the method shown in the margin at right. In the center of the panel, I find a good blow with a “no-mar” mallet is the quickest way to get a workpiece back “in line.”

Centering the pressure on the thickness of the workpieces is a lit-

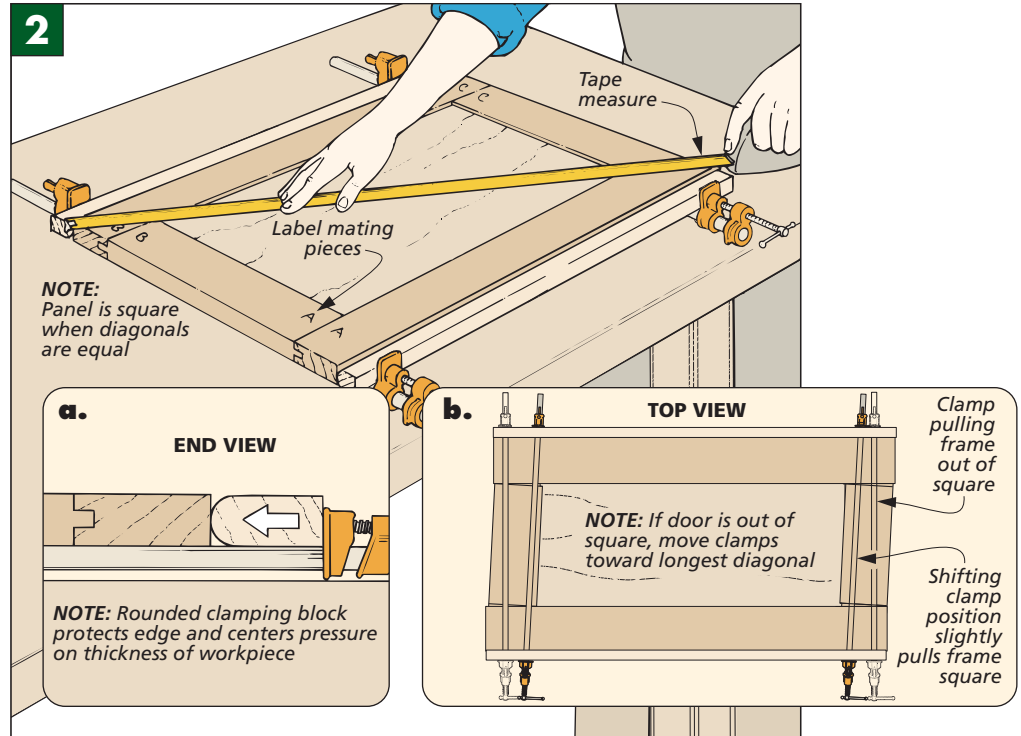

tle different with a frame assembly. In these cases, just one clamp is used at each end, like you see in Fig. 2. Here, to center the pressure, I like to use clamping blocks with rounded edges that are the same thickness as the workpieces. These blocks are slipped between the clamps and the workpieces, like you see in Figs. 2 and 2a.

SQUARE FRAMES. With frames, there is the additional concern of ending up with an assembly that's square. Checking if it's square is easy — just measure the diagonals, as shown in Fig. 2. If these dimensions are the same, the panel is square. If not, you can shift the clamps slightly toward the longer diagonal and retighten them (Fig. 2b).



▲ Tightening a clamp across the end of a joint line draws the surfaces of the boards flush.

APPLYING GLUE & CLAMPING

It seems there are two glue-up questions that I hear a lot: “How much glue should I use?” and “How much clamping pressure is enough?” There's no simple answer to either question. It takes some experience

to determine what each joint needs. One thing I can tell you is that in both cases, more is *not* better.

Applying too much glue just gives you a lot of squeeze-out to clean up later (creating other prob-

lems). What you need is a thin, even coat, as shown in the first photo.

Besides applying too much glue, another common mistake is to try to make up for a poor fit by increasing clamping pressure. Even the strength of Hercules won't make a joint any stronger. Once the pieces have made contact or the joint has closed, apply just enough additional pressure to hold the pieces in position. A thin bead of glue should appear along the joint line, as in the second photo.



▲ **How much glue?** A strong joint needs a thin, even layer of glue. Spread the glue with a brush or piece of scrap.



▲ **How much pressure?** Apply clamping pressure until an even bead of glue forms along the joint line.

Case Assemblies

With panels and frames, you want to end up with flat assemblies. When gluing up a box-type assembly (like a drawer or cabinet case) the goal is to clamp up assemblies that are square.

A back that's set into rabbets will make this job a lot easier. It can be set in place (at least temporarily) to help square up the pieces (Fig. 1).

And if the case doesn't have a back, then a simple squaring form does the same thing (Fig. 1a). A piece of hardboard or plywood sized to fit inside the case is all you need. And by clipping the corners, you don't have to worry that it'll become a permanent part of your assembly.

SEQUENCE. Open, four-sided boxes are fairly straightforward to assemble. Add a divider or some fixed shelves, as in Fig. 2, and you'll need to do a bit more planning.

While my initial inclination is to clamp up the sides first, it's often easier to work from the inside out, as you can see in Fig. 2. And many times, a large case is best tackled in two stages. (Taking a little extra time when dry assembling will help you find the best procedure.)

Large assemblies are also hard to hold together while you're getting the clamps in place. But you can quickly cut a couple of extra "hands"

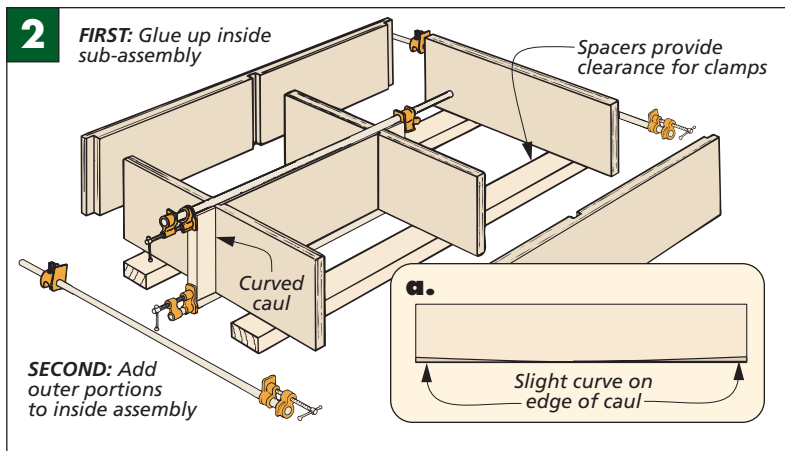
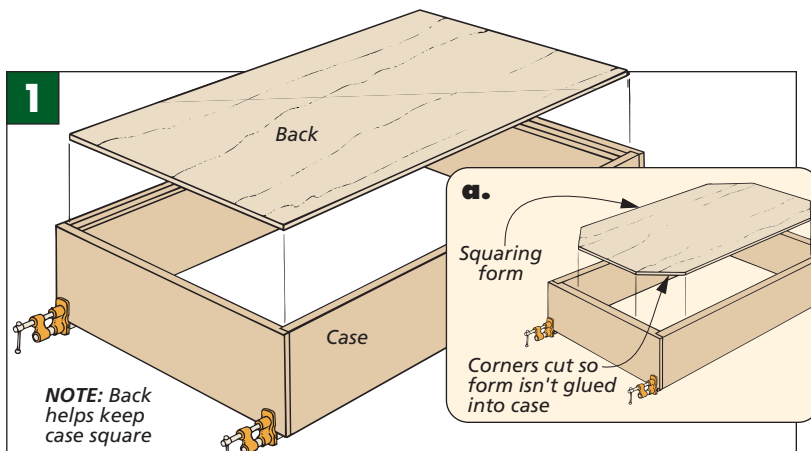

▲ These assembly blocks help hold parts of a case until the clamps can be positioned. Just cut a pair of intersecting dados in pieces of scrap.

to help you temporarily hold the pieces, as shown in the left margin.

CAULS. Wide boxes and cases present an additional challenge — getting the pieces pulled tight across the entire width of the joint. Since clamps put pressure only on the out-

side edges of the joint, you're often left with a gap at the center. The solution here is a caul — a scrap piece with a slightly curved edge (Fig. 2a). This curve extends the "reach" of the clamp heads so the center of the joint is pulled tight.

SQUARING GAUGE

A common way to check an assembly for square is to measure the diagonals. When the measurements are equal, you've got a square assembly.

GAUGE. While a tape measure will work for this, I often use a simple squaring gauge. This way, I don't have to remember dimensions that change as the assembly is adjusted.

If you look at the detail in the drawing at right, you'll see that this gauge is just a couple of narrow pieces of scrap that slide against each other. One piece has a slot that accepts a bolt and a dowel that serves as a guide. Tightening a wing nut locks the gauge at a specific length. And one end of each

piece is tapered to fit tightly into the corners of the assembly.

USING GAUGE. To use the gauge, just loosen the wing nut and extend the ends of the gauge into opposite corners of the box, as shown in the drawing. Snug the wing nut just enough to keep the gauge from sliding. (This makes it easier to adjust the gauge as you check the diagonals.)

Now position the gauge across the other diagonal. If one diagonal is longer, squeeze those two corners toward each other and adjust the clamps. Check the diagonals again and repeat the process until the diagonals are of equal length.

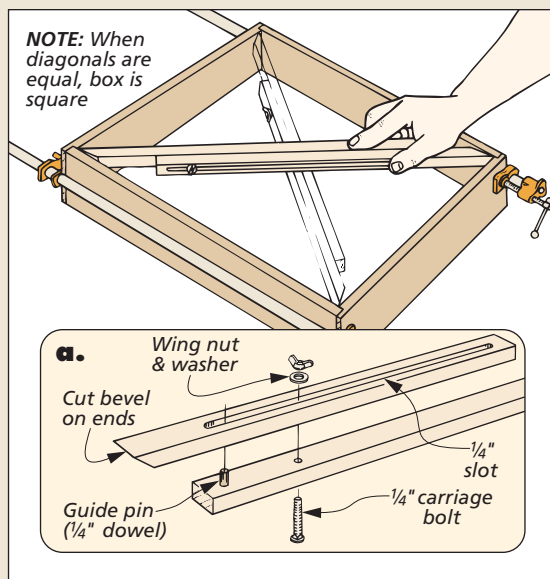

Edging

When plywood is used in a project, you have to consider how to hide the plies on any exposed edges. One way to do this is by applying hardwood edging. The photo at right shows an example — the lid of a plywood chest.

CLAMPING BLOCK. Getting even pressure across a narrow edging strip would require lots of clamps positioned close together. The solution shown in Fig. 1 is to use a wide clamping block. Like clamping wider boards in a panel, this spreads out the pressure from each clamp.

To keep the clamping pressure

centered on the edging, two things can be done. First, elevating the plywood on a spacer strip aligns the center of the panel with the head of the clamp (Fig. 1a). And second, the edge of the clamping block is rounded to direct the pressure to the center of the edging.

EXTENDING CLAMPS. When gluing edging on a long piece of plywood, you may not have clamps long enough to reach the length of the panel. Fig. 2 shows a way to get the job done with shorter clamps. All you have to do is clamp an anchor

block across the panel and then run your edging clamps to the anchor block.

TAPING. There are some projects where the edging isn't applied until after the case is assembled. If the back of the case is already in place, there's no way to get clamps onto the edging. A little trick I use in these situations is shown in Fig. 3. A few strips of packing tape can be used to hold the edging in place while the glue dries.

▲ To hide the edges of the plywood, the lid of the storage chest is wrapped with hardwood edging.

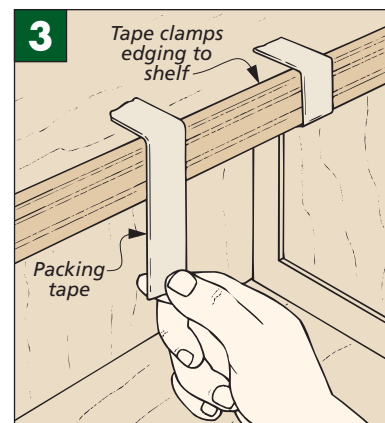
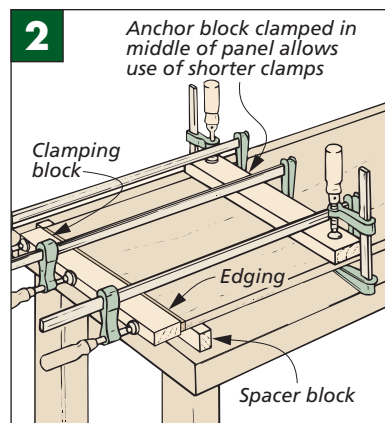
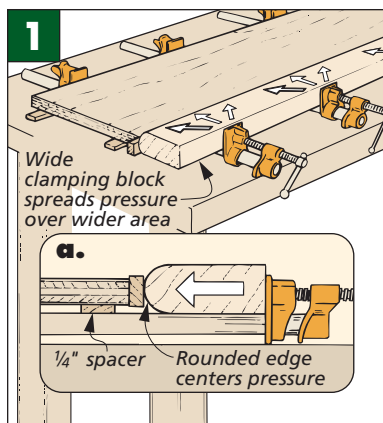

Face to Face

I've found the biggest challenges when gluing workpieces face to face are keeping the pieces in place and clamping them securely.

To fasten two large, flat surfaces together, I'll usually use contact cement. It bonds the pieces in place instantly. But there have been times when I need to be able to make some slight adjustments as the pieces are brought together, or I

need a stronger bond than contact cement provides. In these cases, I'll use yellow glue. The problem is that when the pieces are pressed together, they tend to slide around, like they've been greased.

BRADS & SCREWS. One way to get around this is to drive a couple of brads into one workpiece and snip off the heads, as shown in Fig. 1. When the two pieces are pressed

together, the brads "bite" into the mating piece and keep it in position. And since it can be tough to get clamps to the middle of the workpieces, screws will help secure the pieces while the glue dries.

CAULS. For larger areas, cauls (like those used for case assemblies) come in handy. The curved edge puts pressure in the middle of the panel, as shown in Fig. 2. **W**

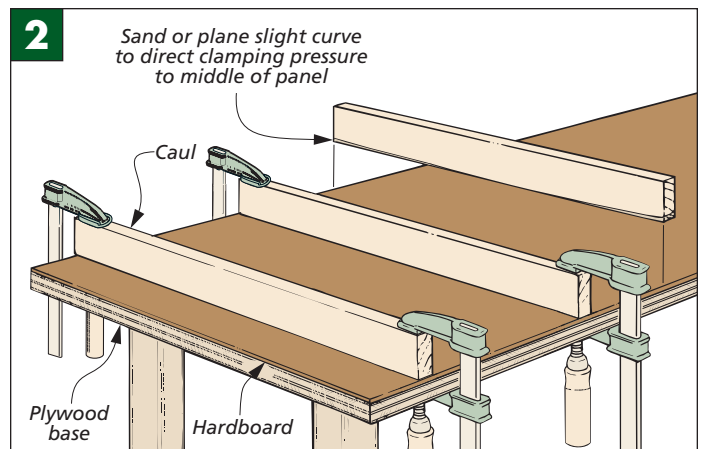
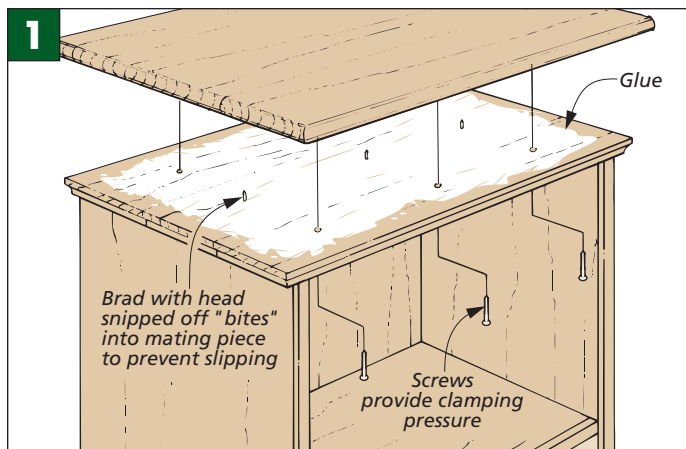

CLAMP STORAGE

*Have some scrap plywood and an empty bit of wall space?
That's all you need to get your clamps organized.*

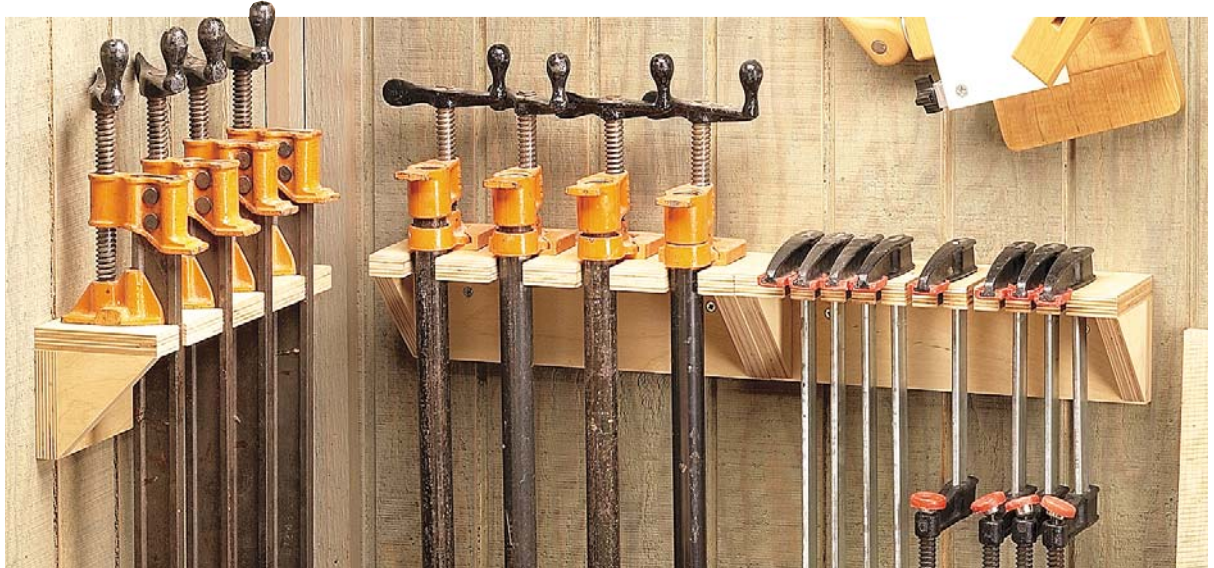

There's an old saying that a woodworker can never have too many clamps. I know that over the years I've collected quite a few. In fact, finding space to put my ever-growing collection was becoming an issue.

What I needed was a better way to store and organize my clamps. And the new "system" had to be easy to build and add on to. That way, as I got more clamps I could make a new rack for them quickly.

SIMPLE DESIGN. What I came up with is a rack that can be made from four small pieces of plywood and fits just about anywhere. A series of these racks can be customized to hold all types of bar and pipe clamps. And as you can see in the photos below, I even made a couple of extra racks to hold gluing supplies and C-clamps.

One thing all the racks have in common is that they are designed to screw to the wall. So you can fit

clamp storage wherever you have an open bit of wall space.

ROLL-AROUND CADDY. If you're short of wall space, don't worry. The racks can also be attached to a handy roll-around caddy. In fact, even if you have plenty of wall space, you may want to consider building the caddy anyway. It holds all of your clamps in one place and makes it easy to roll them to wherever your project may be.



▲ A storage box keeps glue and accessories organized. Mounting it near the clamps makes it handy.



▲ C-clamps are held on this simple rack. It can be custom built to fit different sizes of clamps.



▲ Pistol-grip clamps can be cinched down on a rack, ready to grab and be put to work.

Racks

The heart of this clamp storage system is an L-shaped rack braced at each end by a triangular support. Each rack is the same size. The only difference is the slots that are customized for different types of clamps.

All of the pieces are made from $\frac{3}{4}$ " plywood (although hardwood would work as well). In fact, I built my racks from pieces of scrap plywood that were too small for projects but too big to throw out.

To keep things simple, I made each rack $12\frac{1}{2}$ " long. That way they fit in small bits of wall space as well as on the optional roll-around caddy. But they can be made any length you like to accommodate your clamps.

CUT PIECES. The first step was to cut a top (A), back (B), and two supports (C) to size for each rack, like you see in Fig. 1. (I made the supports by ripping a long $3\frac{1}{4}$ "-wide blank, then making alternating 45° cuts on the end.)

Before assembling the racks, I took the time to drill a couple of countersunk holes in each back piece (Fig. 1a). These are used to screw the completed rack to a wall.

SLOT LAYOUT. The next step is to lay out the slots for the clamps in each top piece. The detail drawings in Figure 1 show racks for the most common types of clamps. Small bar clamps sit fairly close together (Fig. 1b). I-beam clamps need more room between slots (Fig. 1c). And Fig. 1d shows the spacing for pipe clamps. Note: Racks for pistol-grip clamps don't need slots. Refer to the lower right photo on the [previous page](#).

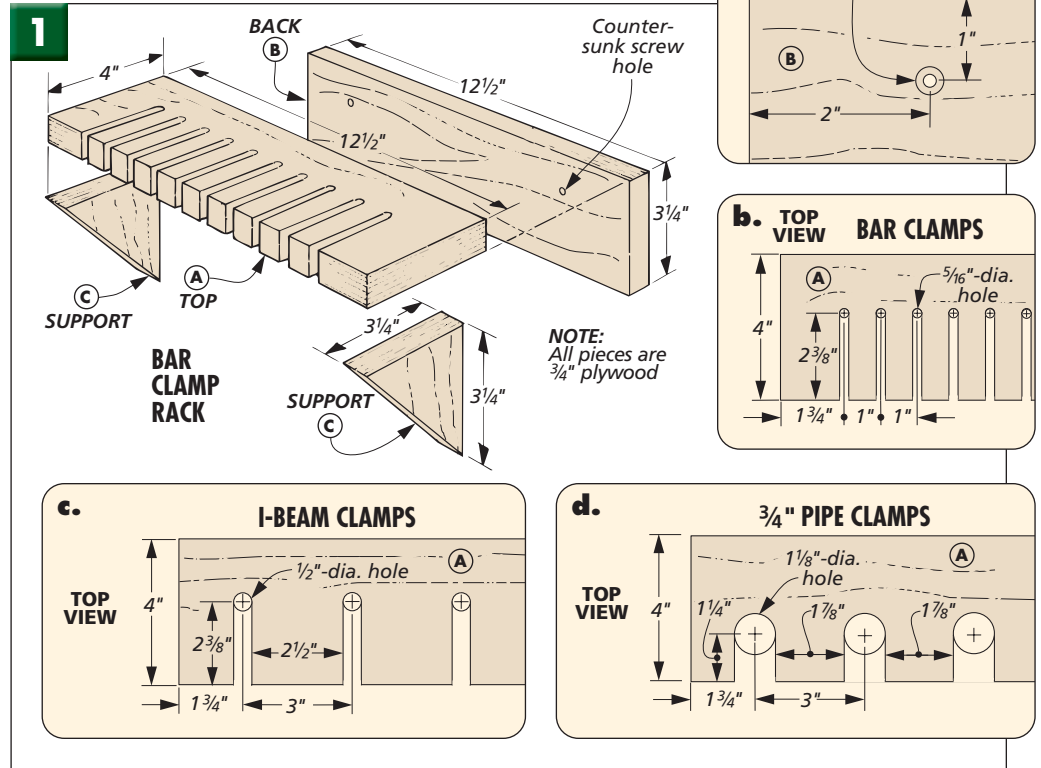

CUT SLOTS. After the slots are laid out, you can start cutting them. I found the best way to do this was to drill a hole at the top of each slot first, like you see in Fig. 2.

After the holes are drilled, the waste can be removed on the table saw. As Fig. 3 shows, I attached an auxiliary fence to my miter gauge to support the workpiece and prevent the waste piece from kicking back.

ASSEMBLY. Once the slots are cut, the rack can be glued up. The top is clamped to the top edge of the back; then the supports are added.

With my long clamps taken care of, I turned my attention to my C-clamps and accessories.

MATERIALS

BAR & PIPE CLAMP RACK

- A Top (1) $\frac{3}{4}$ ply. - 4 x $12\frac{1}{2}$
- B Back (1) $\frac{3}{4}$ ply. - $3\frac{1}{4}$ x $12\frac{1}{2}$
- C Supports (2) $\frac{3}{4}$ ply. - $3\frac{1}{4}$ x $3\frac{1}{4}$

C-CLAMP RACK & STORAGE BOX

- D C-Clamp Back (1) $\frac{3}{4}$ ply. - $3\frac{1}{4}$ x $12\frac{1}{2}$
- E Dowels (2) $\frac{3}{4}$ dia. x $5\frac{1}{2}$
- F Box Front (1) $\frac{3}{4}$ ply. - 4 x $12\frac{1}{2}$
- G Box Back (1) $\frac{3}{4}$ ply. - $4\frac{1}{2}$ x $12\frac{1}{2}$
- H Box Sides (2) $\frac{3}{4}$ ply. - 4 x $4\frac{1}{2}$
- I Box Bottom (1) $\frac{3}{4}$ ply. - $4\frac{1}{2}$ x 11

CLAMP CADDY

- J Sides (2) $\frac{3}{4}$ ply. - 14 x 48
- K Bottom (1) $\frac{3}{4}$ ply. - 14 x $25\frac{1}{2}$
- L Divider (1) $\frac{3}{4}$ ply. - $25\frac{1}{2}$ x $47\frac{1}{2}$
- M Base (1) $\frac{3}{4}$ ply. - 22 x 28

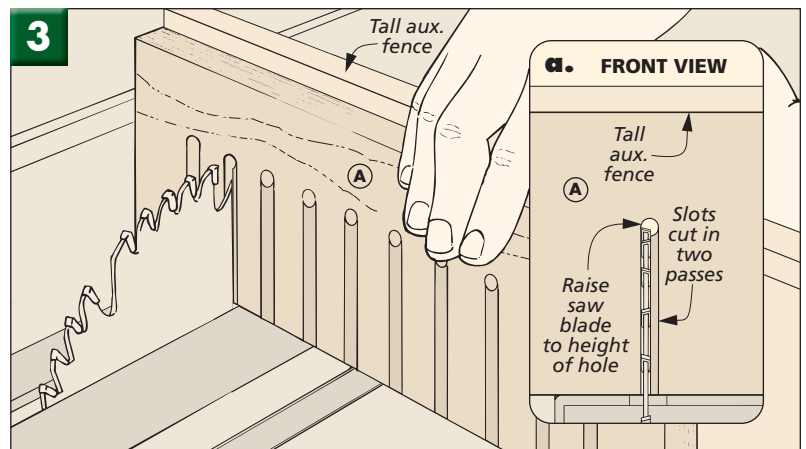
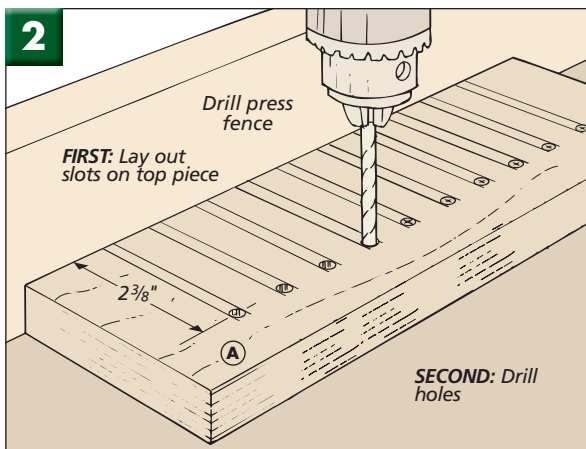



C-Clamp Rack

To keep 4" C-clamps in order, I made this small rack. It's nothing more than a pair of short $\frac{3}{4}$ " dowels attached to a plywood back.

If you take a look at Fig. 4a, you can see that the holes for the dowels are drilled at a slight angle. This keeps the clamps from sliding off the front. For larger or smaller C-clamps, just change the spacing between the dowels. The completed rack is then screwed to the wall.

▲ C-clamps hang neatly on a rack made with a plywood back and a couple of dowels.

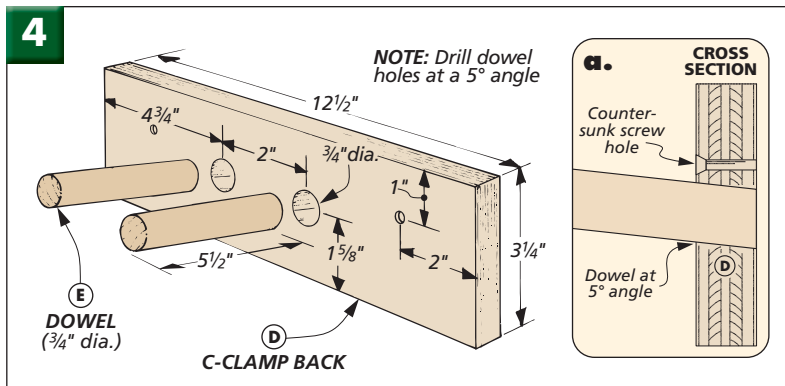

Storage Box

Once you start a glue-up, you can't really stop to hunt for some accessory you forgot. That's why I like this simple storage box. It gives me one convenient place to keep bottles of glue, clamp pads, band clamps, brushes, and other odds and ends that seem to "wander off" just as I'm ready to start a glue-up.

Like the racks, the box is made from $\frac{3}{4}$ " plywood. And keeping with the modular design of the storage system, the box is the same length as the racks. If you look at Fig. 5, you can see one thing that's a little unusual about the box — the back is $\frac{1}{2}$ " taller than the front. As you can see in Fig. 5a, this allows

▲ A storage box will hold gluing accessories and keep them close at hand during assemblies.

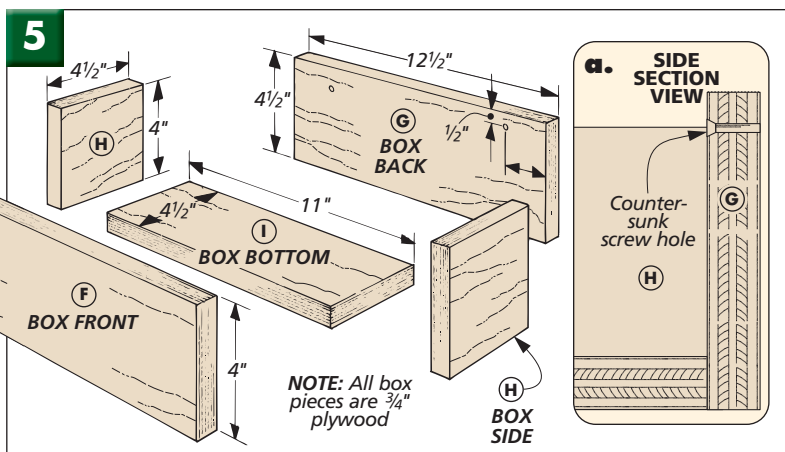

the mounting screws to be up higher so they can be reached easily with a screwdriver. (It's a good idea to drill the holes for these screws before the box is glued up.)

Assembly of the box is simple. I spread glue on all four edges of the bottom piece, then sandwiched it between the sides before adding the front and back pieces.

ALTERNATIVE MOUNTING OPTIONS

These small racks don't take much wall space. Even so, the weight of the clamps will play a big part in where and how you mount the racks.

Pegboard will be suitable for a short rack with small clamps. But it may not be strong enough to hold a rack filled with long pipe clamps.

If you're fastening the racks to drywall, try to find one stud to screw into. The other end of the rack can be attached with a drywall anchor.

Solid wood or plywood (like on the caddy on page 8) will provide the strongest mounting surface for heavy racks.

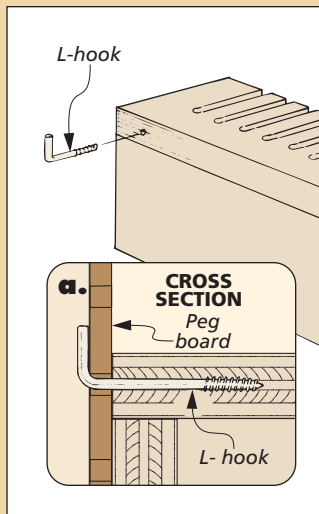

Pegboard. L-screws driven into the edge of the top allow you to hang a rack on pegboard.

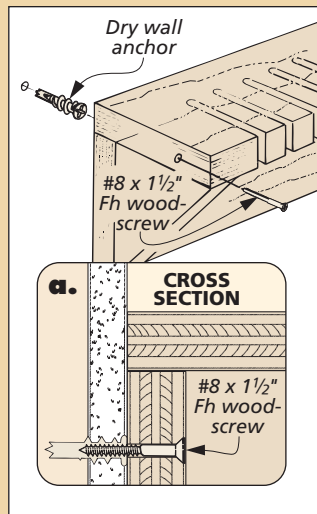

Drywall. Hollow wall hangers will hold a rack, but try to drive at least one screw into a stud

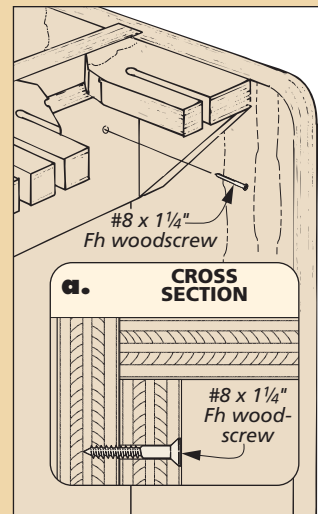

Caddy. To fasten racks to the caddy, drill pilot and shank holes and use woodscrews.

Optional Clamp Caddy

While the clamp racks are designed to be small enough to fit just about any available wall space, you might want to consider building this roll-around caddy to hold them. It provides plenty of room to fasten clamp racks and storage boxes.

Two clamp racks will fit between the sides. As shown in the photos below, more racks can be fastened to the outside faces. And best of all, the caddy is mounted on locking swivel casters, so it's easy to roll it to wherever you need it.

The caddy can be made from a single sheet of plywood (with enough left over to make a few racks). The pieces fit together with a series of dados and rabbets.

CONSTRUCTION. There are only five pieces in the caddy. So the place to start is by cutting the sides (J), bottom (K), divider (L) and base (M) to size, as shown in Fig. 6.

Next, dados are cut in the sides and bottom to fit the divider (Fig. 6a). Then as Fig. 6b shows, the side pieces also receive a rabbet that accepts the bottom panel.

Before assembling the caddy, I rounded the corners of the base to make it "ankle friendly" (Fig. 6c). The top corners of the sides receive the same treatment.

ASSEMBLY. To assemble the caddy, first glue the divider to the bottom and then add the sides. A few screws along the dados and rabbets help reinforce the joints.

There are just a few small things left. One is to screw a locking swivel caster to each corner of the base, as

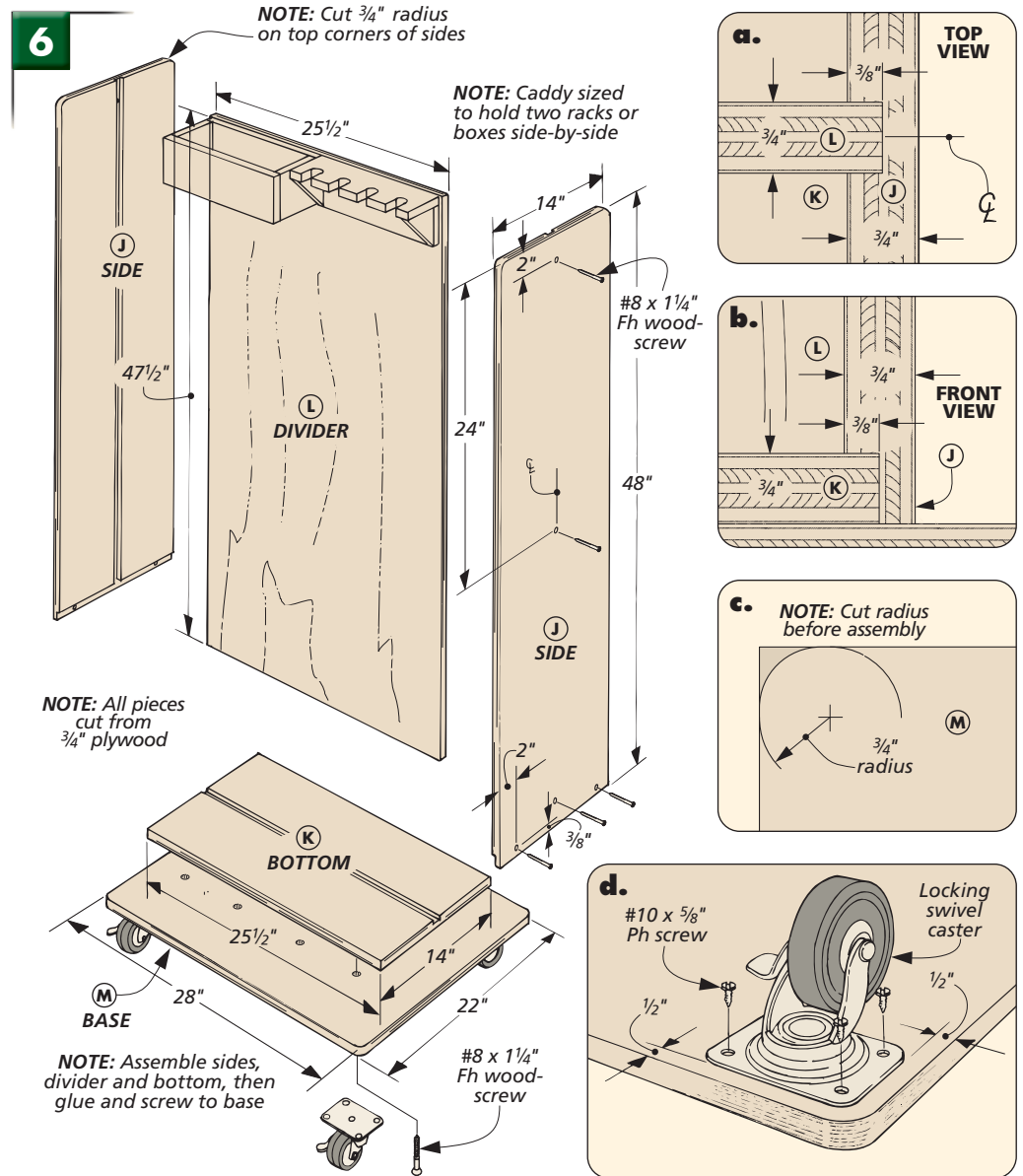

shown in Fig. 6d. Then the caddy assembly is centered on the base and glued and screwed down. Finally, you can attach the racks and fill them with clamps. **W**

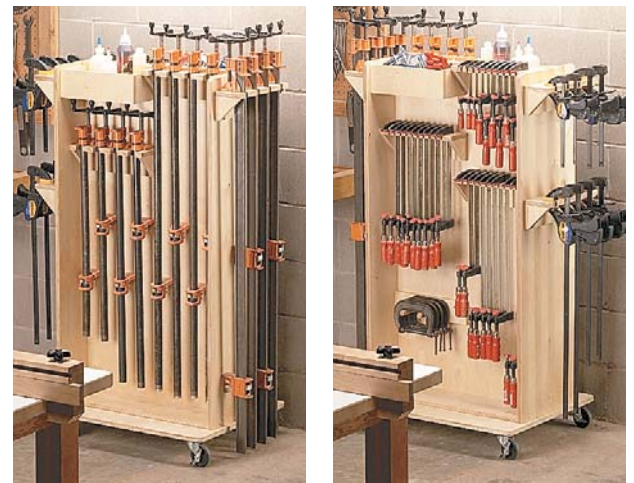

▲ **Take it for a spin.** The four casters on this caddy make it mobile, so you can wheel it over to an assembly and have your clamps (and accessories) right at hand. Plus, the casters allow you to spin the caddy around easily, which means quick access to the clamps on all four sides.

CUTTING DIAGRAM

3/4" - 48" x 96" Maple Plywood

